

NovoDoser®

L series 800SC

A new generation liquid nitrogen doser with frost-free operation, food grade austenitic stainless steel material, hygienic wash-down design in compliance to stringent HACCP requirement



Specifications

- Discrete dosing up to 800 CPM
- Controller with Siemen S7-1200 PLC platform
- NEMA 4X IP65 stainless steel enclosure
- HMI comes with TFT color touch screen
- Minimum dose duration 15mS
- Accurate dose weight +/-2%
- No container No dose function
- Smart-maintenance to allow user plan the maintenance schedule
- Direct LN2 feed pressure up to 30psi (2.0 Bar)
- ModBus user interface
- Alarm log to assist system trouble shooting and performance monitoring
- Recipe storage up to 5 recipes
- 316L material construction higher corrosion resistance
- Optional HS Pneumatic Hygienic Dosing Head wash-down design
- Multi-lingual HMI: English, Spanish, Chinese, etc

Ergonomic Features and Benefits

- **Frost-free Nozzle** – Self-generating GN2 for dosing head blanketing
- **Lowest LN2 Consumption** – Discrete dosing, for speed up to 800 containers per minute
- **Lowest LN2 Losses** – Proprietary vacuum insulation with lowest heat leak 0.1 LPH
- **Minimized Product Splash** – Lowest dose pressure in its class, 0.3 psi
- **Sub-cooled LN2** – Ensuring constant LN2 density for accurate dosing
- **Corrosion Resistant** – 316L material grade of construction for doser body
- **Highest Hygiene Design** – All external surface has rounded corners and sloped design for easy wash-down
- **Lowest Maintenance** – Ultra long life cycle dosing valve > 60 million; and IP 65 rated sensors & electrical cables
- **Ease of Installation** – Compact size for easy installation in limited space
- **Applications Flexibility** – Compatible with soft-dose and micro-dose technology for hot fill, powder, and granular applications
- **5 Years Vacuum Warranty** – Lowest cost of ownership

NovoDoser® L series 800SC

Dimensions

Material	Stainless Steel 300 Series
Head Pressure	0.3psi
Nozzle Blanketing	Self-Generate N2
Steady State Consumption	< 0.026 gal (0.10 liter) / hour
Body Dimension	36"H x 5"W (910 x 129mm)
Dosing Head Dimension	EA Head 6.4"H x 2"W (162x45mm)
Dosing Head Arm Reach	18" (457mm)
Weight	30lbs (14kg)
Utilities	Liquid Nitrogen : 22 psi Gaseous N ₂ : 60 - 100 psi Electrical : 110-220VAC

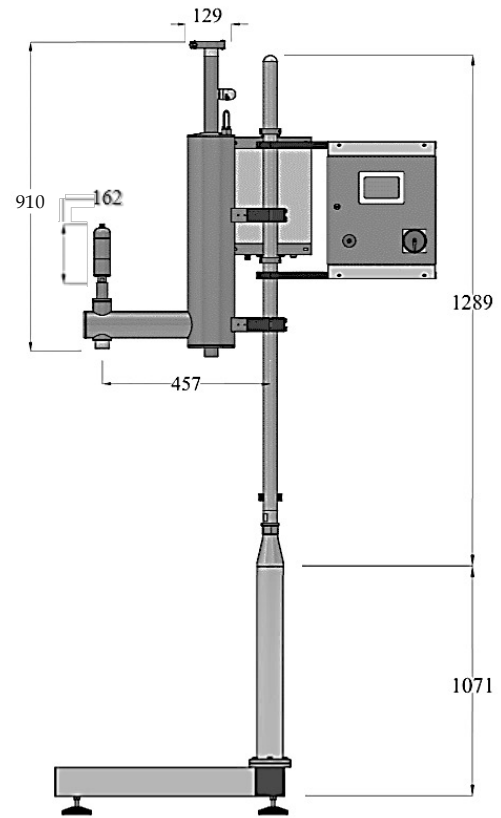

800SC Controller Specifications

PLC Platform	Siemens S7-1200
HMI (LCD touch screen)	4.3" Color
Dose Duration, 1ms int.	15 to 1500 ms
Dose Volume, mg/dose	10 to 1400
Dose Accuracy	± 2%
Max. Discrete Dosing	800 CPM
Fixed Delay	✓
Speed Compensation	✓
Dose Compensation	✓
Quick Service Purging	✓
Nozzle Defrost	Automatic
Nozzle Pre-Cooling	Manual
Modbus RTU User Interface	✓
Overall Equipment Effectiveness	✓
Recipe Storage	5
HS Hygienic Dosing Head	Optional
Certifications	CE, IP65

