

NovoDoser®

H series 1000DSC

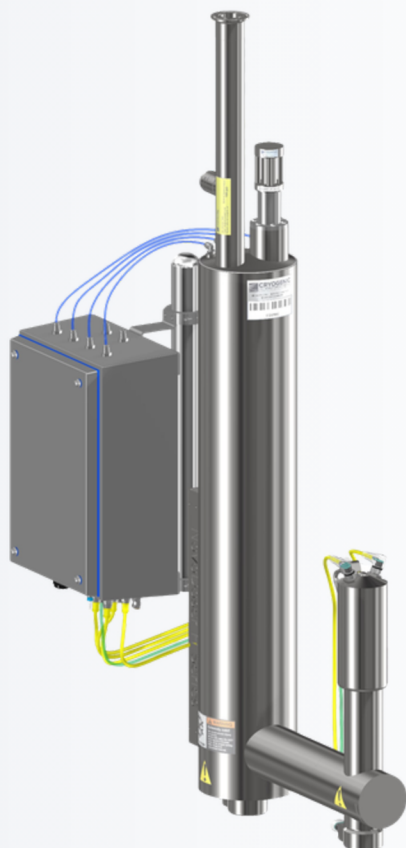

A new generation liquid nitrogen dosing system with advanced control for precise and frost-free dosing, designed for line speed up to 2000 CPM and superior vacuum quality with 5 years warranty.

Specifications

- LN₂ inlet pressure up to 100 psi (6.8 bar)
- Integrated inlet safety relief valve 150 psi (10.3 bar)
- Discrete dosing up to 2000 CPM
- Minimum dose duration 5 ms
- Dose accuracy +/- 2%
- Electro-pneumatic dosing valve, IP67 rated
- Dose Timing Synchronization
- Dose Volume Synchronization
- Rapid nozzle defrost
- Nozzle pre-cooling
- Quick System Purging, Dry down & Warm-up
- Alarm log to assist system troubleshooting and performance monitoring
- Recipe storage up to 12 recipes
- Multi-lingual HMI: English (US/UK), German, Spanish, Chinese, etc.
- Controller with Siemens S7-1200 PLC, 7" TFT color touchscreen HMI, NEMA 4X IP65-rated stainless steel enclosure

Ergonomic Features and Benefits

- **Frost-free Nozzle** – Self-generating GN₂ for dosing head blanketing
- **Lowest LN₂ Losses** – Proprietary vacuum insulation with lowest heat leak 0.11 LPH
- **High Dosing Speed** – Higher dose pressure in its class, 0.55 psi
- **Sub-cooled LN₂** – Ensuring constant LN₂ density for accurate and repeatable dosing
- **Corrosion Resistant** – Stainless steel 300 series material grade
- **Highest Hygiene Design** – All external surface has rounded corners and sloped design for easy wash-down
- **Lowest Maintenance** – Ultra-long life cycle dosing valve, tested 100 million
- **Ease of Installation** – Compact size for easy installation in limited space
- **Applications Flexibility** – Compatible with GentleDose and micro-dose technology for hot fill, powder, and granular applications
- **5 Years Vacuum Warranty** – Lowest cost of ownership

NovoDoser[®] H series Dimensions

Material	Stainless Steel 300 series ^[1]
Head Pressure	0.3 - 0.55 psi
Nozzle Blanketing	Self-Generated N ₂
Steady State Consumption	< 0.029 gal (0.11 L) / hr
Body Dimension	42" H x 5" W (1070 H x 129 W mm)
Dosing Head Dimension	<u>Servo Electric (ES Head)</u> 21" H x 3.1" W (534.6 H x 78 W mm) <u>Optional: Electro-pneumatic (HS Head)</u> 14" H x 2.5" W (354 H x 63.5 W mm)
Dosing Head Arm Reach	18" (457 mm)
Weight	35 lbs (16 kg)
Utilities	Liquid Nitrogen LN ₂ : ≤ 100 psi Gaseous Nitrogen GN ₂ : 100 psi Electrical: 110-220 VAC

^[1] SS316/316L for external material

^[2] H-frame base and Ø88.9 support stand are available as options, customer to provide "A" dimension when ordering.

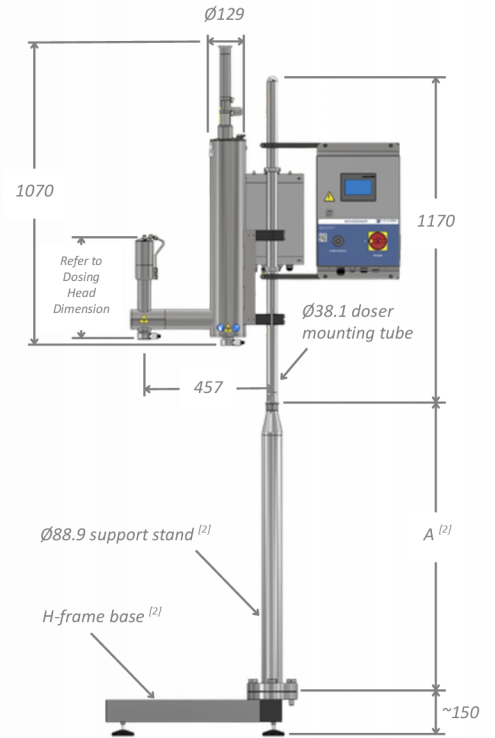

Controller Specifications

Model	1000DSC-X
PLC Platform	Siemens S7-1200
HMI (LCD touchscreen)	7.0" Color
Dose Duration, 1 ms interval	5 ^[3] to 1500 ms
Dose Volume, mg/dose	5 ^[3] to 1400
Dose Accuracy	± 2%
Max. Discrete Dosing	2000 CPM
Continuous Dosing Line Speed	2000 CPM
Dose Timing Synchronization	Synchronized with filler signal
Dose Volume Synchronization	Synchronized with filler signal
Thermo-Purging	
- Quick System Purging	✓
- Rapid Nozzle Defrosting	
- CIP Protection	
Nozzle Pre-Cooling	Auto
Filler Command Signal	✓
Filler Signal Exchange	✓
Modbus RTU User Interface	✓
Recipe Storage	12
Certifications	CE

^[3] 10 for HS Actuator

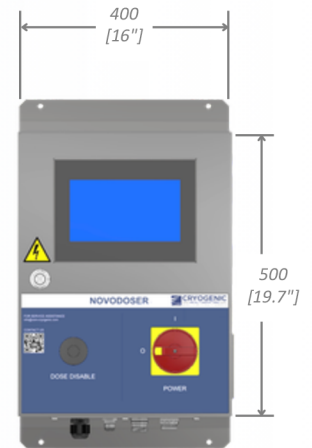

All dimensions provided are for indication purposes only and may not accurately represent the actual product dimensions. Please contact us for updated and actual measurements.