

Phase Separator

Vertical

Pressure Adjustable



Stainless steel, floor-mounted vertical type vacuum jacketed cryogenic conditioning system designed to supply LN₂ at user required pressure setting. Once the system has been set up, the liquid level and pressure is automatically control by the controller. The controller comes with a HMI to allow user to set their required pressure.

Vertical Phase Separator - Pressure Adjustable

Pressure adjustable vertical Phase Separator is used for stepping down the pressure of liquid nitrogen in the pipeline. This is done by venting out excessive vapor while maintaining a constant liquid supply capacity for downstream consumption. The result is a high quality liquid nitrogen with precise pressure control at the user's point of use. CSM Phase Separator is a vacuum insulated reservoir holding tank for liquid nitrogen with a pressure & level control system. The controller will operate its inlet proportional control valves to regulate the liquid level, and another vent proportional valve to regulate the user's required set pressure.



All Phase Separators comes with CSM renowned customer service, from conceptual design to implementation, and are backed by a 5-years Vacuum Warranty, & 1-year Defect Warranty.

Typical Applications

- Test Handlers in semiconductor IC Assembly and Test
- Environmental Chambers
- Bottling Lines and Packaging
- Food Freezing

Related Products:

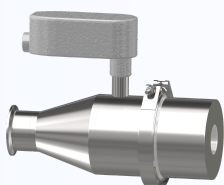

Vent Heater

Features and Benefits

- Consistent liquid nitrogen delivery, dramatically improving process control and efficiency
- User friendly operator controls with level & pressure alarm
- Vacuum insulated vessel and control valve for frost free operation
- User adjustable output pressure for all models
- HMI with digital display of liquid level and pressure readings
- Modbus output available

Phase Separator Specifications

Model	V22P	V76P
Operational Capacity* / Full Capacity	6 gal (22 L) 10 gal (33 L)	20 gal (76 L) 30 gal (115 L)
Outlets (Vertical)	1 (C5)	1 (B15)
Max. Inlet Pressure Max. Back Pressure	145 psi (10 bar) 87 psi (6 bar)	145 psi (10 bar) 87 psi (6 bar)
Vessel MAWP	150 psi (10.3 bar)	
Max. Withdrawal Rate	5 GPM (19 LPM)	40 GPM (150 LPM)
Weight - Empty - Full	926 lbs (420 kg) 981 lbs (445 kg)	1136 lbs (515 kg) 1334 lbs (605 kg)
Level Control Sensor	Capacitance	
Vacuum Insulation	Static Vacuum only	
System Utilities	Electricity: 80-240 VAC; GN2: 40-140 psi (2.7- 9.7 bar)	
Materials	NEMA 4X, CE	
PLC Platform	Siemens S7-1200	
HMI (LCD touchscreen)	7.0" Color	
Standard Testing	Dimensional Check He Leak Checked @ 1×10^{-9} cc/s	
Optional	Pneumatic Pressure Test, Vacuum Retention Testing, LN2 Cold Shock Testing, CFOS Cleaning for O2 Services, X-ray Inspection, Pre-Material Certs., ASME-coded Pressure Vessels BPVC Section VIII Certification	

* Factory preset operational capacity, field adjustable by user depending on liquid flow output requirement, and in-coming liquid saturation characteristics

Phase Separator Dimensions

Model	H1	H2	H3	L1	L2
V22P	40" (1009 mm)	44" (1106 mm)	62" (1561 mm)	16" (410 mm)	23" (571 mm)
V76P	71" (1808 mm)	74" (1871 mm)	111" (2808 mm)	20" (500 mm)	26" (410 mm)

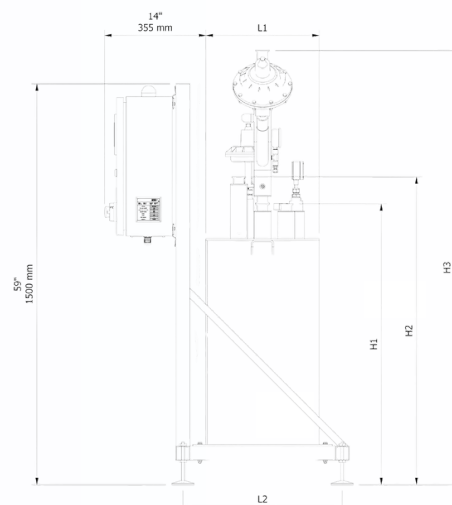

All dimensions provided are for indication purposes only and may not accurately represent the actual product dimensions. Please contact us for updated and actual measurements.