

Cryogenic Subcooler

Vertical



An advanced liquid nitrogen subcooler, engineered to deliver a guaranteed **77 K (-196 °C)**, zero-vapor liquid quality to your process, regardless of your storage tank's level, pressure and insulation conditions. By transforming standard LN₂ into a subcooled state with extremely low enthalpy, we eliminate flash-off, ensure maximum thermal transfer efficiency and precise temperature control with flow rates of up to **3,500 kg/hr**.

Typical Applications

- **Biopharmaceutical Lyophilization:** Rapid freezing of vaccines, antibodies, and other sensitive biologics
- **Exothermic Chemical Reactor Cooling:** Immediate and precise heat removal for highly reactive chemical processes
- **Precision Cryogenic Machining:** Machining of super alloys (e.g., Inconel, Titanium) with minimal thermal distortion precision and superior surface finishing
- **Nuclear Reactor Emergency Cooling:** Rapid and high-capacity heat sink for emergency shutdown and core cooling
- **Aseptic Dosing Systems:** Stable, vapor-free liquid nitrogen for accurate and repeatable dosing in pharmaceutical and beverage packaging applications
- **Blanketing and Inerting:** Protective, oxygen-free environments in chemical vessels and food packaging to prevent oxidation, contamination, and unwanted reactions
- **Aluminum Extrusion:** Rapid heat removal from the extrusion dies for higher production speed, better surface quality and reduced oxidation

Ergonomic Features and Benefits

- **Lowest Coolant Losses** – Super vacuum insulation with lowest heat leak
- **High Efficiency Subcooling** – Maintains constant liquid density for stable, high-quality performance
- **User-defined Pressure** - Keeps outlet pressure equal to inlet pressure (up to 10 bar) for reliable and consistent operation
- **Corrosion Resistant** – Built from stainless steel 300 series for durability and long service life
- **High Mass Flow Rate** – Handles capacities from 500 - 3500 kg/hr to fit wide range of operational needs
- **Lowest Maintenance** – Designed for hassle-free operation with minimal service requirements
- **Ease of Installation** – Plug-and-play setup for quick, skill-free installation
- **Applications Flexibility** – Suitable for LN₂, LO₂, LAr, and LNG, covering diverse cryogenic applications
- **5 Years Vacuum Warranty** – Lowest cost of ownership

Cryogenic Subcooler vertical

Specifications

Models	CSV.500	CSV.1500	CSV.3500
Subcooling Rate	500 kg/hr	1500 kg/hr	3500 kg/hr
Max. Process Inlet Pressure	150 psi (10 bar)		
Bath Pressure	Atmospheric		
Bath Level Control	Automatic (Pneumatic)		
Weight - Empty	80 kg (lbs)	120 kg (lbs)	250 kg (lbs)
Weight - Full Process & Bath	120 kg (lbs)	200 kg (lbs)	450 kg (lbs)
Vacuum Insulation	Static		
Material	Stainless Steel 300 series*		
Bath Level Control	Cryo-Stic Level Sensor		
Certifications	NEMA 4X, CE		
Standard Testing	Dimensional Check He Leak Check at 1×10^{-9} cc/s		
Optional Services	Vacuum Retention Testing, LN2 Cold Shock, Pre-material Certification, X-ray, ASME B31.3 Certification, CFOS Cleaning for O2 Application		
Utilities	Liquid Nitrogen LN ₂ : ≤ 150 psi (10 bar) Gaseous Nitrogen GN ₂ : 87 psi (6 bar) Electrical: 80-240 VAC		

Cryogenic Subcooler vertical

Dimensions

Models	L1	H1	H2
CSV.500	16.0" (406 mm)	29.3" (744 mm)	39.6" (1005 mm)
CSV.1500	19.7" (500 mm)	34.6" (880 mm)	45.7" (1160 mm)
CSV.3500	23.6" (600 mm)	57.1" (1450 mm)	66.9" (1700 mm)

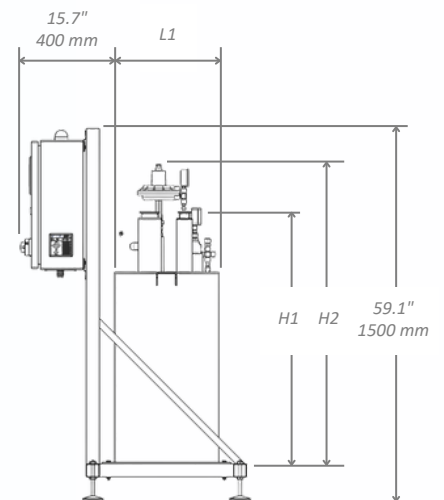

All dimensions provided are for indication purposes only and may not accurately represent the actual product dimensions. Please contact us for updated and actual measurements.