

V200

The V200 valve with PTFE stem seal is engineered for minimal stem leakage and reliable operation under extreme cryogenic condition. Its unique top entry valve stem design allows for quick and easy in-line maintenance.

PTFE Stem Seal Valve

Constructed from SS304 stainless steel, the V200 features a live-loaded PTFE stem seal design that prevents stem leakage and ensures leak-free operation throughout its service life. The valve body and bonnet extension is vacuum-jacketed to provide superior thermal insulation, minimizing heat ingress, external frost formation, and cryogen boil-off.

An optimized body and trim enhances flow performance with improved Cv and minimal pressure drop while maintaining class VI bubble-tight shutoff. The modular top-work assembly allows for efficient in-line maintenance and reduced downtime. Configurable with manual, pneumatic, or electric actuation, the V200 adapts easily to a wide range of cryogenic fluids and temperatures.

Each valve is designed for 10,000 cycles of leak free operation, ensuring consistent performance and reliability in demanding cryogenic environments.



All PTFE Seal Valve product comes with CSM renowned customer service, from conceptual design to implementation, and are backed by 1-year Defect Warranty.

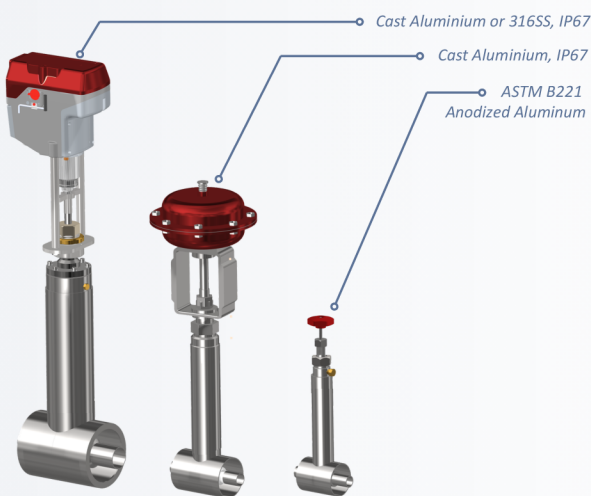

Multi-Actuation Options:
Manual, Pneumatic or Electric

Features and Benefits

- Vacuum Jacketed Design minimizes heat transfer and external condensation
- Orbital Welded Construction ensures superior cleanliness and process integrity
- Enhanced Cv Performance through optimized flow path design
- PTFE Stem Seal minimizes stem leakage
- Modular Top-work Stem Assembly allows fast in-line maintenance and reduced downtime
- Compliant with ASME B16.34 / MSS-SP-134 / ISO 15848
- Engineered to operate at -454°F to +302°F (-270°C to +150°C), suitable for liquid nitrogen and other cryogenic fluids at MAWP 300 psi (20 bar)
- Standard CFOS cleaning for O2 services to CGA G-4.1, EIGA IGC 33-18, and ASTM G93
- Standard Dimensional Check, He Leak Test at 1.0×10^{-9} cc/s, Seat Seal Bubble Tight Test at 300 psi (20 bar) N₂ gas, Packing Mass Test at 1.0×10^{-5} Torr
- Optional Pre-material certs., Test to MSS-SP-134, X-ray, ASME B16.34 certification, RPTSTD-8070-0001

PTFE Stem Seal Valve Material Specifications

No.	Part	Material
1	Body	316SS/304SS, ASTM A479
2	Body Stub Pipe	304SS, ASTM A479
3	Body Jacket	304SS, ASTM A479
4	Bonnet	Nickle-plated Brass, ASTM B16
5	Body Neck Tube	304SS, ASTM A479
6	Body Neck Jacket	304SS, ASTM A479
7	Plug	Brass, ASTM B16 Optional: 316SS, ASTM A479
8	Seal	C-PTFE, ASTM D1430
9	Seal Retainer	Brass, ASTM B16
10	Seal Screw	304SS, ASTM A479
11	Sleeve Retainer	304SS, ASTM A479
12	Retaining Ring	316SS/304SS, ASTM A479
13	Stem	304SS, ASTM A479
14	Stem Sleeve	PTFE, ASTM D1710
15	Upper Body	304SS, ASTM A479
16	Union Nut	Nickle-plated Brass, ASTM B16
17	Secondary Bonnet Seal	Silicon, ASTM D2000
18	Primary Bonnet Seal	PTFE, ASTM D1710
19	Packing Nut	Nickle-plated Brass, ASTM B16
20	Packing Gland	Brass, ASTM B16
21	Inner Wiper Ring	FKM, AMS 7276
22	Outer Wiper Ring	Silicon, ASTM D2000
23	Chevron Packing	PTFE, ASTM D1710
24	Packing Support	Brass, ASTM B16
25	Handwheel	Anodized Aluminum, ASTM B221
26	Handwheel Nut	Steel, AS 1112
27	Vent Plug	Brass, ASTM B16

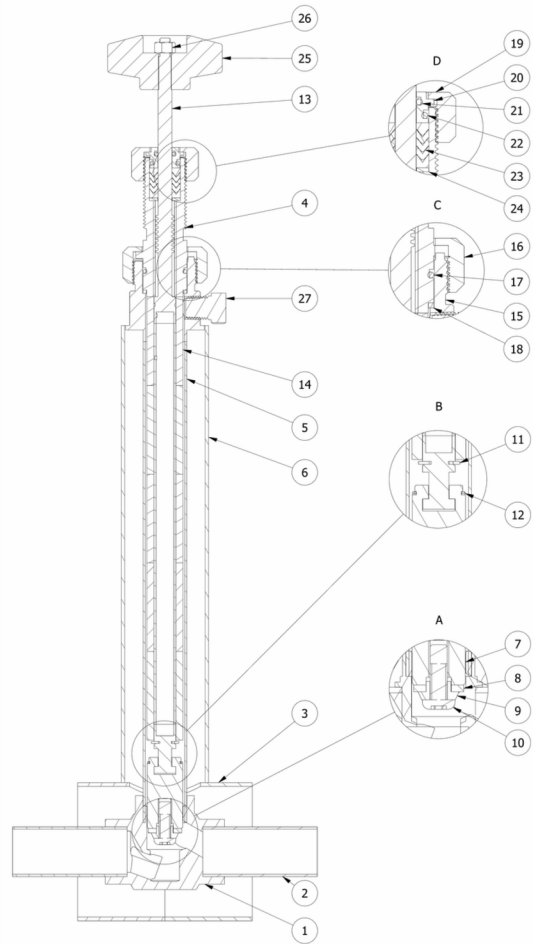

PTFE Seal Valve Dimensions

Valve Size	A	B	C	D	E Manual	H1 Pneumatic	H2 Electric
1/2"	0.84" (21.3 mm)	2.38" (60.3 mm)	3.00" (76.2 mm)	4.0" (101.6 mm)	14.4" (366 mm)	20.6" (524 mm)	17.9" (455 mm)
1"	1.32" (33.4 mm)	3.50" (88.9 mm)	5.00" (127.0 mm)	7.0" (177.8 mm)	17.4" (442 mm)	23.3" (591 mm)	20.9" (531 mm)
1 1/2"	1.90" (48.3 mm)	5.56" (141.2 mm)	7.00" (177.8 mm)	10.0" (254.0 mm)	22.5" (572 mm)	25.9" (657 mm)	34.5" (877 mm)
2"	2.38" (60.3 mm)	5.56" (141.2 mm)	7.00" (177.8 mm)	10.0" (254.0 mm)	22.5" (572 mm)	31.0" (788 mm)	34.5" (877 mm)
3"	3.50" (88.9 mm)	6.63" (168.4 mm)	9.00" (228.6 mm)	13.0" (330.2 mm)	25.3" (643 mm)	-	-
4"	4.50" (114.3 mm)	6.63" (168.4 mm)	9.00" (228.6 mm)	13.0" (330.2 mm)	25.3" (643 mm)	-	-

